

FOR OFFICIAL USE

--	--	--	--	--	--

National  
Qualifications  
SPECIMEN ONLY

Mark

--

**SQ22/H/01**

**Graphic  
Communication**

Date — Not applicable

Duration — 2 hours



Fill in these boxes and read what is printed below.

Full name of centre

--

Town

--

Forename(s)

--

Surname

--

Number of seat

--

Date of birth

Day

Month

Year

D	D
---	---

M	M
---	---

Y	Y
---	---

Scottish candidate number

--	--	--	--	--	--	--	--	--	--

Total marks — 70

Attempt ALL questions.

Write your answers clearly in the spaces provided in this booklet. Additional space for answers is provided at the end of this booklet. If you use this space you must clearly identify the question number you are attempting.

All dimensions are in mm.

All technical sketches and drawings use third angle projection.

You may use rulers, compasses or trammels for measuring.

In all questions you may use sketches and annotations to support your answer if you wish.

Use **blue** or **black** ink.

Before leaving the examination room you must give this booklet to the Invigilator; if you do not, you may lose all the marks for this paper.



Attempt ALL questions

Total marks — 70

MARKS DO NOT WRITE IN THIS MARGIN

1. A public building that was constructed in the 1950s is to be modernised. The original drawings were produced manually in paper format. The architect has requested that the manual drawings be converted to a digital format and sent electronically.

The conversion methods being considered are: scanning the original drawings or reproducing the drawings using CAD software.

- (a) (i) Compare the two methods in terms of their suitability for this task.

4



1. (a) (continued)

- (ii) Explain two possible disadvantages that may be encountered when two different people or companies work together on the same project using CAD.

2

CAD simulation could be used to test aspects of the design of the building.

- (b) Identify an aspect of the design that could be tested through a CAD simulation.

1

- (c) Identify an advantage of a "paperless office" to an architectural business.

1



2. The sketches below were used by a CAD technician to create a 3D model of a portable speaker casing. The 3D model will be used to make production drawings and a promotional illustration.

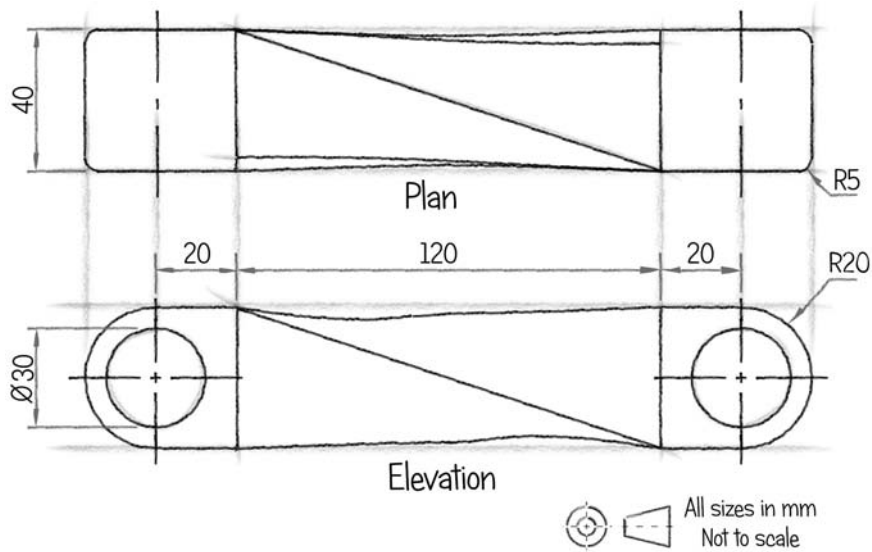

Orthographic sketch

The CAD technician sketched a modelling plan before creating the 3D model. The first two stages of the modelling plan are shown below.

- (a) Describe the 3D modelling techniques proposed for each stage, making reference to all relevant dimensions from the orthographic sketch. You can sketch, annotate the sketches provided and/or use text in your answer.

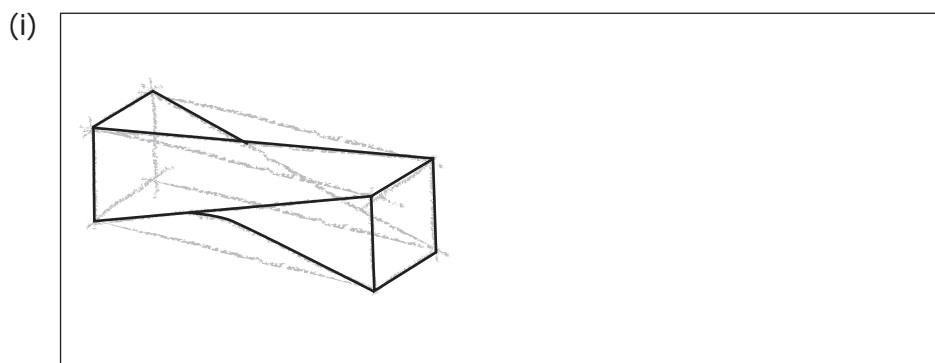

2

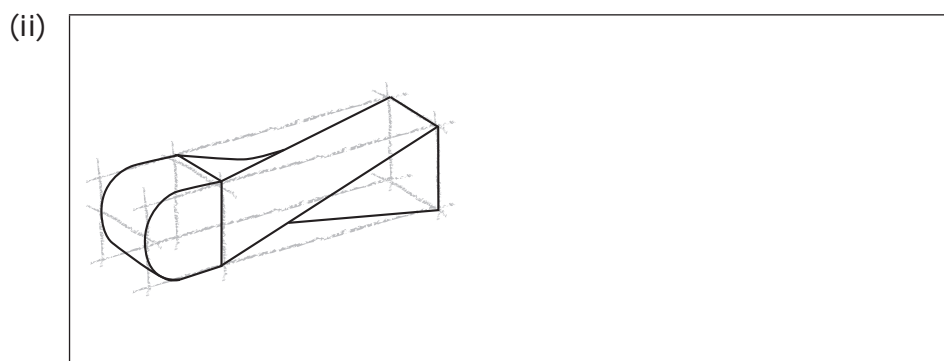

2



2. (continued)

Solid model of the portable speaker casing



Component parts of the portable speaker casing

A solid model of the portable speaker casing and the two components generated from it are shown above.

- (b) Describe, using a "top-down" approach, the techniques used to create the two component parts from the solid model. You can sketch, annotate and/or use text in your answer.

4

2. (continued)

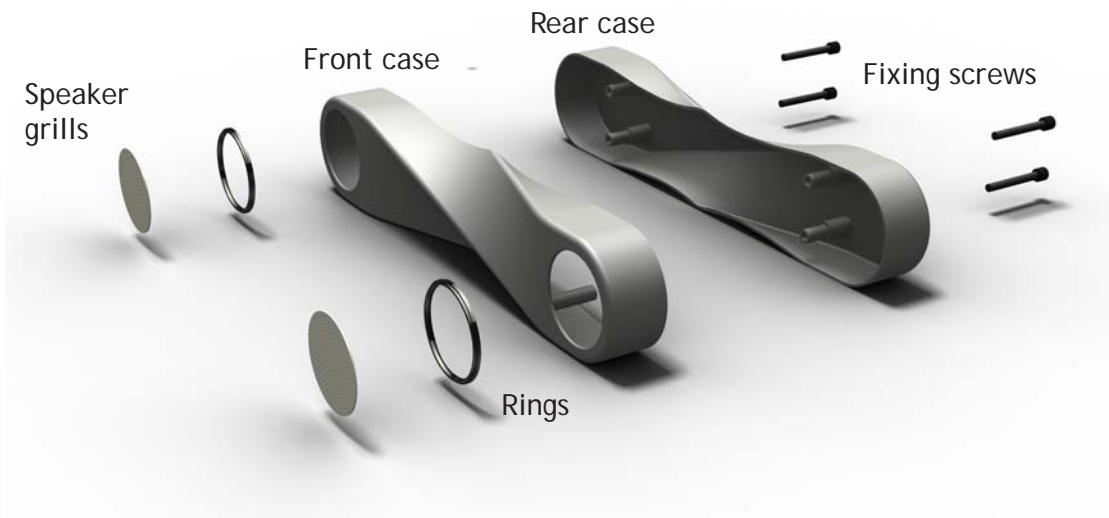

The components of the speaker casing are shown above.  
The fixing screws were imported from a CAD library.

(c) Explain why this type of component would be included in a CAD library. 2



MARKS

DO NOT  
WRITE IN  
THIS  
MARGIN

2. (continued)



The two component parts of the portable speaker casing need to be assembled within the CAD software.

(d) Outline the 3D modelling techniques used to fully constrain the two component parts. You may use annotated sketches to support your answer if you wish.

2



\* S Q 2 2 H 0 1 0 7 \*

2. (continued)

MARKS  
DO NOT  
WRITE IN  
THIS  
MARGIN

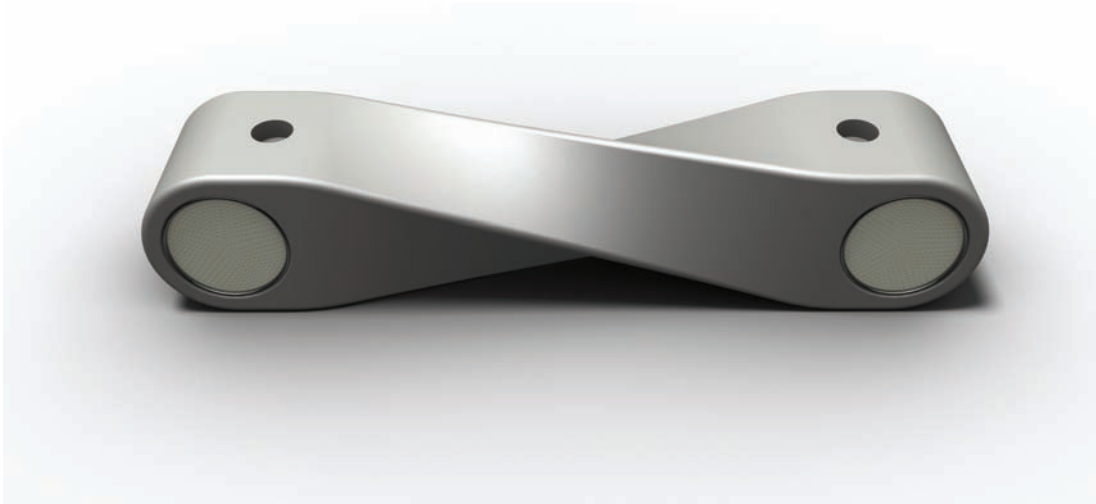
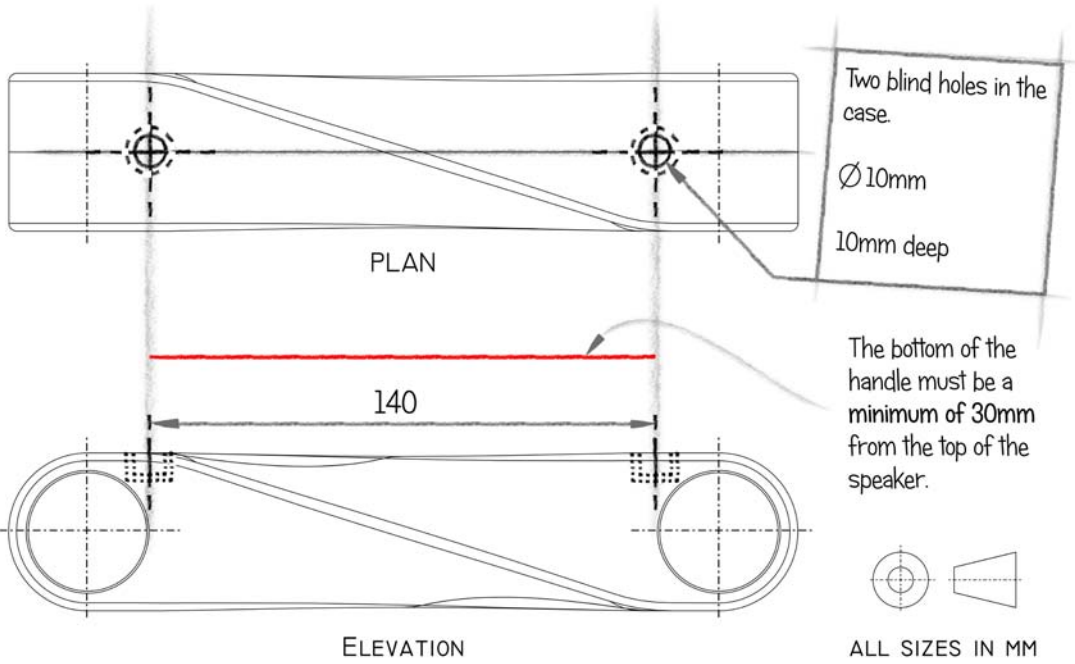



## 2. (continued)

The portable speaker casing design has been modified to allow a simple handle to be attached. These modifications have been sketched on the production drawings and shown on the 3D model on the left.

- (e) Produce a modelling plan which could be used to create a 3D CAD model of a simple handle to fit the blind holes in the casing. The handle will be glued into the holes. You can sketch, annotate, and/or use text in your answer.

4

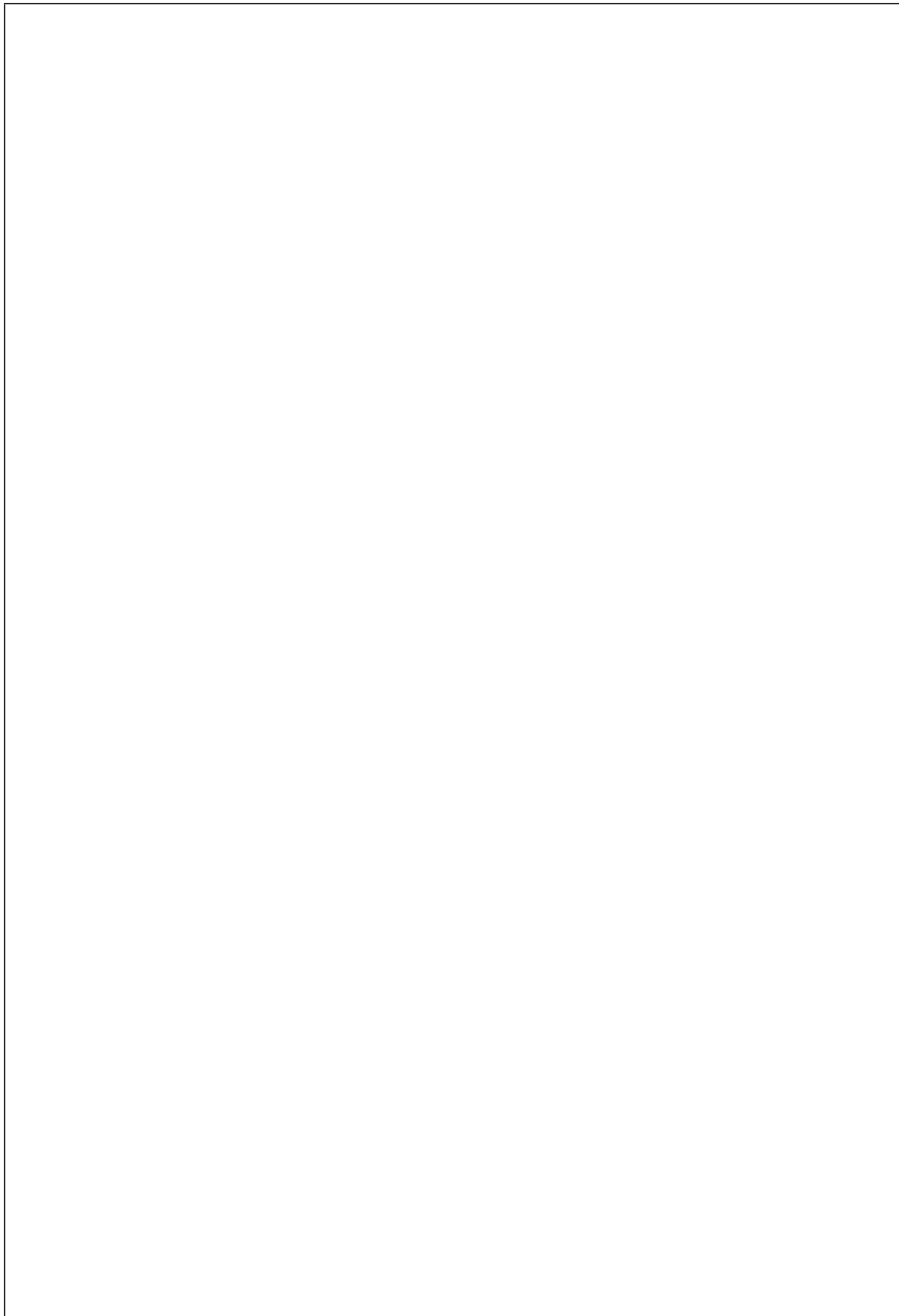

\* S Q 2 2 H 0 1 0 9 \*

3. The promotional layout below is used to attract consumers to a new product.

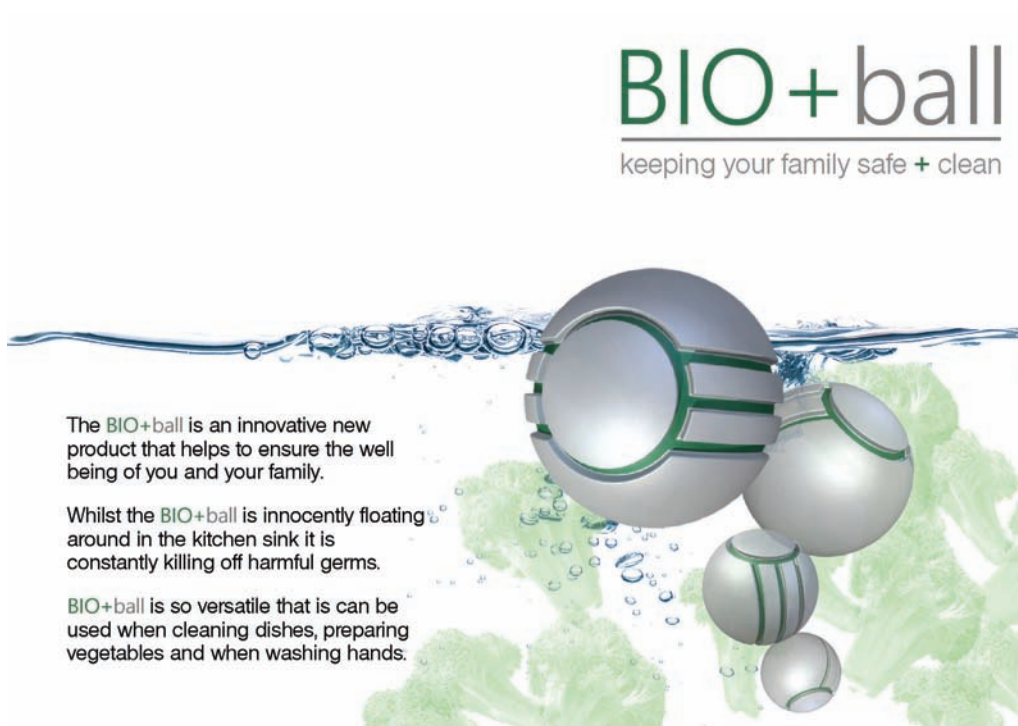

**BIO+ball**  
keeping your family safe + clean

The BIO+ball is an innovative new product that helps to ensure the well being of you and your family.

Whilst the BIO+ball is innocently floating around in the kitchen sink it is constantly killing off harmful germs.

BIO+ball is so versatile that it can be used when cleaning dishes, preparing vegetables and when washing hands.

The image shows a promotional layout for 'BIO+ball'. At the top right, the product name 'BIO+ball' is written in a large, green, sans-serif font, with a horizontal line underlining the 'O'. Below it, the tagline 'keeping your family safe + clean' is written in a smaller, black, sans-serif font. The main visual is a 3D rendering of several silver, spherical balls with green horizontal stripes, floating in water. The water is depicted with blue ripples and bubbles. In the background, there are green leafy vegetables, possibly broccoli, partially submerged. To the left of the balls, there are three short paragraphs of text in a black, sans-serif font, describing the product's benefits and uses.

Explain how the graphic designer has used typeface, colour and choice of images to attract consumers.

4



\* S Q 2 2 H 0 1 1 0 \*

4. Components that make up a pulley wheel assembly are shown below as an exploded view.

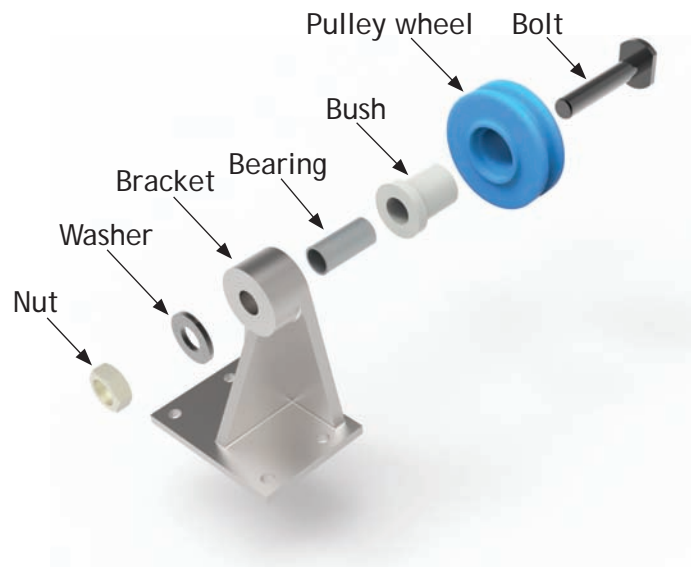

An incomplete sectional elevation, cut along a central vertical plane, is shown below.

- (a) (i) Apply hatching to the assembled elevation to show the different components taking account of British Standards. You may sketch the section lines on the view and you can use a straight edge if you wish.

3

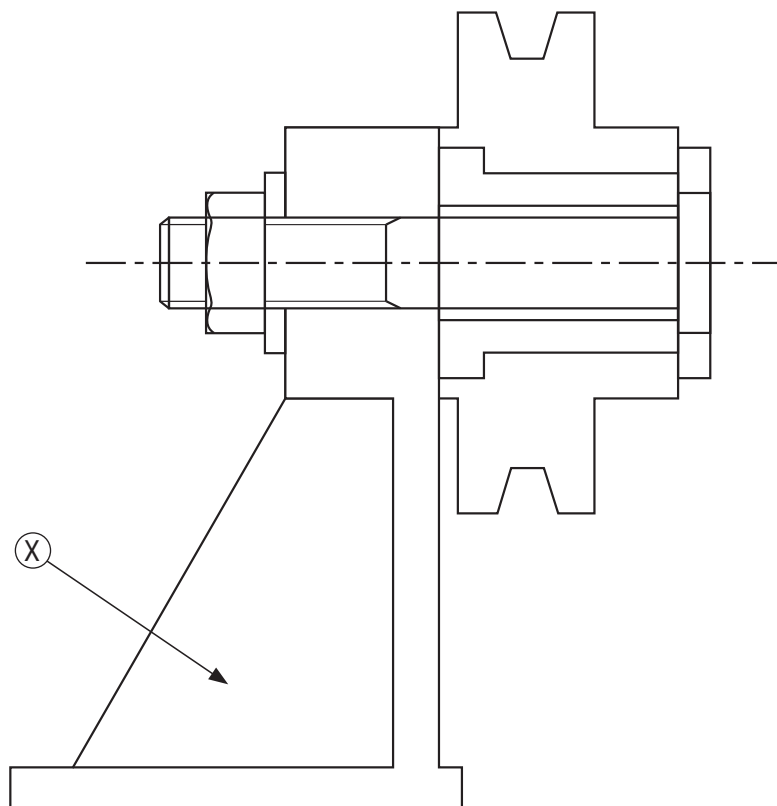

- (ii) State the name for the feature shown at X.

1



4. (a) (continued)

The bolt used in the assembly has flat sections on the end for a spanner to fit.

- (iii) Apply the British Standards convention for this flat on the bolt shown below (Figure 1).

1

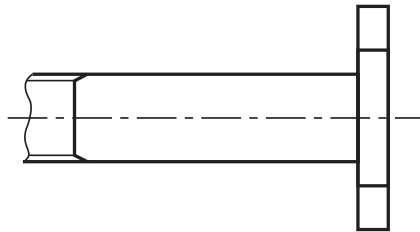

Figure 1

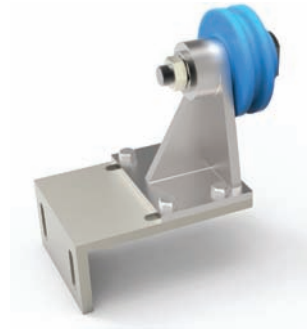

Figure 2

The 3D view in Figure 2 shows the pulley assembly bolted by the base to another component. The drawing below shows the three stages.

Stage 1 — a blind hole is machined in the component

Stage 2 — a thread is cut into the blind hole

Stage 3 — an M10 bolt and washer is fitted to secure the pulley assembly

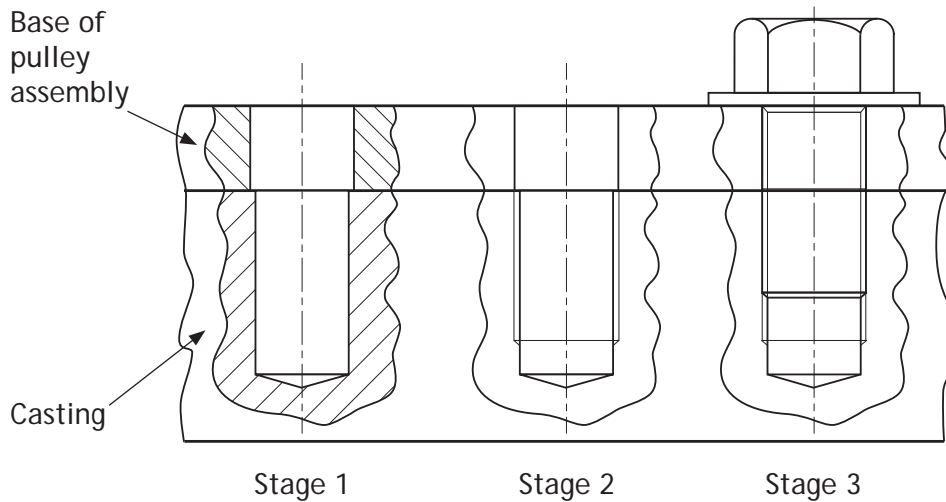

- (b) (i) Apply hatching to Stage 2 and Stage 3 above taking account of British Standards and conventions. You may sketch the section lines on the view and you can use a straight edge if you wish.

2



4. (b) (continued)

(ii) Explain the term "blind hole" at Stage 1.

1

(iii) What does the "M" stand for on the M10 bolt?

1

(iv) Determine the depth of the hole for the thread cut at Stage 2.

1

(v) State the type of section shown at Stages 1 to 3.

1

The holes on the base of the pulley assembly are 10.5 mm with a tolerance of  $-0.15$  and  $+0.15$  applied.

(vi) Apply the dimensional tolerance to the hole in Stage 1 taking account of British Standards.

1



5. The elevation of two interpenetrating cylindrical pipes is shown below. A surface development of interpenetrating cylindrical pipes is being generated using 2D CAD. The elevation and part construction work is shown below.

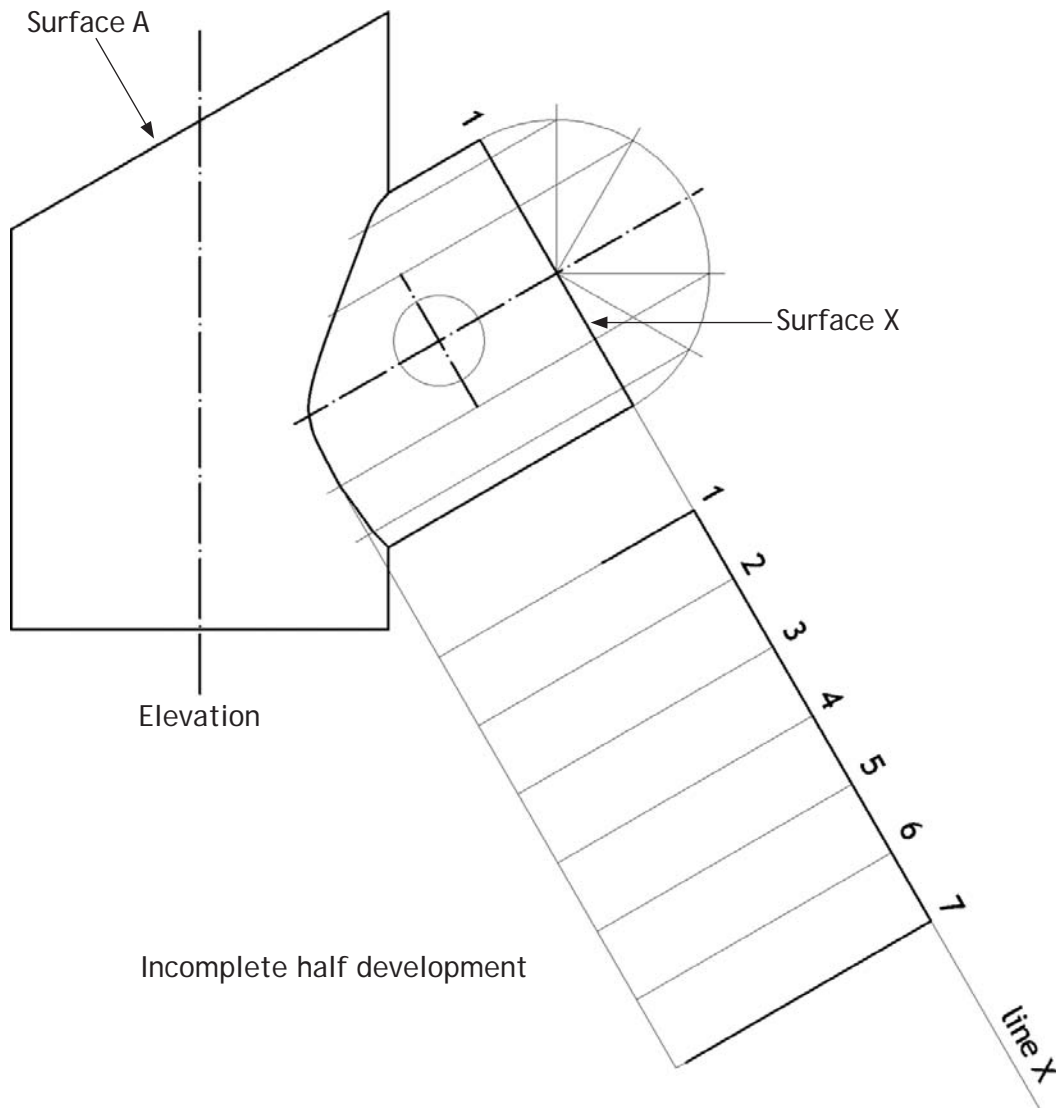

Line X has been drawn and will be offset to the left to create a series of parallel lines to locate the intersection for plotting the points.



5. (continued)

- (a) Complete the table provided indicating the offset required to locate the position of the points on each generator given (1–7) and the centre point for the circle.

2

Generator line	Offset from line X (mm)
1	
2	
3	
4	
5	
6	
7	
Circle centre point	

The true shape of surface A is shown below.

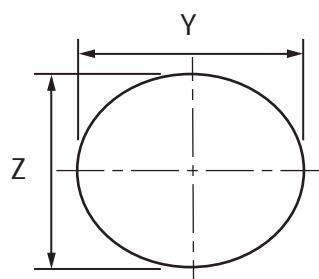

Not to scale

- (b) What are the full dimensions for Y and Z on surface A?

1

Y = \_\_\_\_\_ Z = \_\_\_\_\_



6. Use the three layouts in the **Question 6 supplement** provided to answer this question.

Three promotional layouts for “One Stop Kit Shop”, a cycling accessories chain, are shown.

The layouts are aimed at three different target markets and will be displayed in three different magazines.

Target market layout 1: (45–65 years) male and female, leisure cycling, working and retired singles and couples, grown-up families, TV influences: gardening and travel shows

Target market layout 2: (25–45 years) male and female, working, keen cyclists, adventure cycling, young families or no family commitments, TV influences: sport and Top Gear

Target market layout 3: (15–25 years) predominantly male, serious adventure and mountain biking, single, independent, TV influences: reality shows, indie and grunge music

The graphic designer has used a range of design elements and principles in each of the three layouts to appeal to the different target markets.

(a) Explain why the styles of typeface used in layout 1 will appeal to its target market. 2

(b) Explain how the use of shape enhances layout 2. 2



6. (continued)

In layout 2, three lines, two blue and one orange, are used.

- (c) Explain how each of these lines improves layout 2. Each of your explanations should be different.

3

Advancing and receding colours have been used in each of the layouts.

- (d) Select one of the layouts. Identify an advancing colour used in it, and describe the impact this colour has on the layout.

2

In layout \_\_\_\_\_ the advancing colour is \_\_\_\_\_.

The effect this colour has on the layout is:

Different forms of balance have been used in the layouts. In layout 1 the cyclists are placed off-centre, whilst in layout 2 the cyclist is placed in the centre of the layout.

- (e) (i) Explain one challenge that placing a main item in the centre of a layout gives the graphic designer.

1

6. (e) (continued)

- (ii) Explain the benefit of placing a main item off-centre in a layout (other than your answer to 6(e)(i)).

1

- (f) Explain three different ways in which the graphic designer has used design elements and principles in layout 3 to appeal to its target market.

3



7. Use "The Colour and the Shape" articles (layout A and layout B) from the Question 7 supplement provided to answer this question.

A graphic designer has created a magazine double-page spread for a home furnishing publication as shown in layout A. After development, the graphic designer enhanced the layout and produced a pre-press copy, layout B.

(a) Explain two reasons for using headers and footers in a multi-page document. 2

(b) Examine the feature shown below.

(i) State the name of this feature which is in each corner of layout B. 1



(ii) Explain the purpose of this feature. 1

(iii) Explain why the graphic designer used bleed in layout B. 1

7. (continued)

Examine the layering tree shown below.

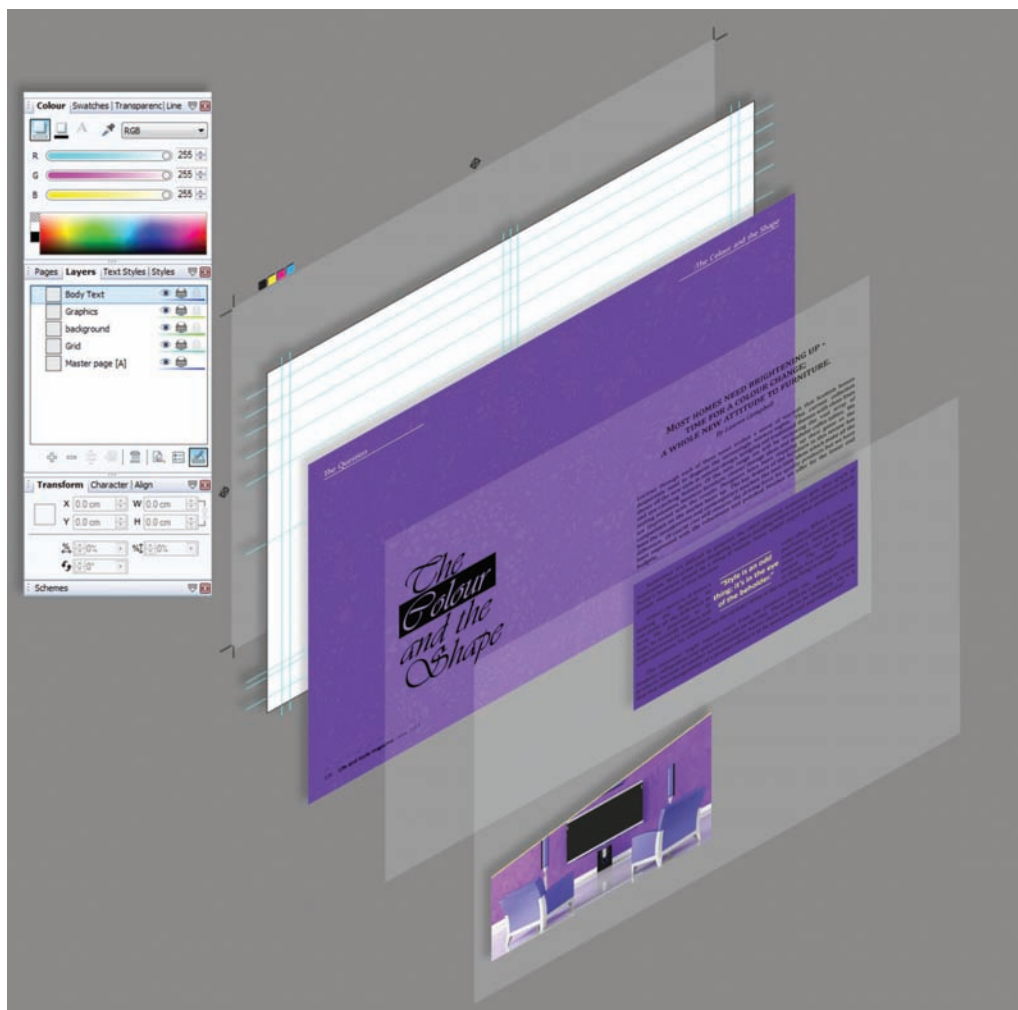

- (c) Describe layering as it is used in layout B in terms of the function and the benefits of layering for the graphic designer.

2



\* S Q 2 2 H 0 1 2 0 \*

7. (continued)

Examine **both** layout A and layout B.

Three DTP improvements have been made from layout A to layout B.

(d) Identify what these improvements are and explain their impact.

(i) Layout improvement 1 is: 2  
  
and the impact is:

(ii) Layout improvement 2 is: 2  
  
and the impact is:

(iii) Layout improvement 3 is: 2  
  
and the impact is:

[END OF SPECIMEN QUESTION PAPER]



\* S Q 2 2 H 0 1 2 1 \*

Layout 1



Layout 2



Layout 3



\* S Q 2 2 H 0 1 2 2 \*



Layout A

The Question The Colour and the Shape

# The Colour and the Shape

**MOST HOMES NEED BRIGHTENING UP -  
TIME FOR A COLOUR CHANGE;  
A WHOLE NEW ATTITUDE TO FURNITURE.**

*By Lauren Campbell*

LOFTING through each of these tones evokes a sense of warmth that Scottish homes desperately need to disguise the increasingly wintery nights. This current collection shows off the new style in interior design, bridging old traditional themes with clean lines and eye-catching features. Of the new range we will be reviewing the vast array of seating solutions, business furniture, clever storage ideas and modular coffee tables. We are impressed with the results. Designers have been stepping up their game as the competition on the market heats up. The key feature of the furniture in this review has been the inventiveness and contemporary touches; the neat little ideas which make all the difference. Of course cost still remains the driving force for quality products but we have been impressed with the robustness and polished finishes on offer for the lower end budgets.



Sometimes it's difficult to pinpoint the exact moment someone gets that spark of inspiration. Most of the time designing is about deciding where to start and when to finish. Today's furniture should be a thing of beauty. Some would argue that aesthetics are of greater importance than function.

Colour choice is, at times a risky affair. When it comes to making the decision to purchase a product, the colour can make all the difference to consumers. Autumnal colours have the potential to fit most tastes and at the same time, be instantly modern and popular trend for minimalism in design has reached its peak with consumers. So, what next for the stylists? What is the next big thing in design?

**"Style is an odd thing; it's in the eye of the beholder."**

The consumer might require more from the products they use. Multifunctional, modular, collapsibles and space savers are on the rise. There could be a demand for these products because of smaller accommodation means there needs to be flexibility. Or, is it that that interchangeability of a product allows it to be more personal and interactive?

106 Life and Style magazine | May 2013 Life and Style magazine | May 2013 107

Layout B pre-press copy

The Question The Colour and the Shape

# The Colour and the Shape

**MOST HOMES NEED BRIGHTENING UP -  
TIME FOR A COLOUR CHANGE;  
A WHOLE NEW ATTITUDE TO FURNITURE.**

*By Lauren Campbell*

**L**OFTING through each of these tones evokes a sense of warmth that Scottish homes desperately need to disguise the increasingly wintery nights. This current collection shows off the new style in interior design, bridging old traditional themes with clean lines and eye-catching features. Of the new range we will be reviewing the vast array of seating solutions, business furniture, clever storage ideas and modular coffee tables. We are impressed with the results. Designers have been stepping up their game as the competition on the market heats up. The key feature of the furniture in this review has been the inventiveness and contemporary touches; the neat little ideas which make all the difference. Of course cost still remains the driving force for quality products but we have been impressed with the robustness and polished finishes on offer for the lower end budgets.



Sometimes it's difficult to pinpoint the exact moment someone gets that spark of inspiration. Most of the time designing is about deciding where to start and when to finish. Today's furniture should be a thing of beauty. Some would argue that aesthetics are of greater importance than function.

Colour choice is, at times a risky affair. When it comes to making the decision to purchase a product, the colour can make all the difference to consumers. Autumnal colours have the potential to fit most tastes and at the same time, be instantly modern and unique.

The recent (and popular) trend for minimalism in design has reached its peak with consumers. So, what next for the stylists? What is the next big thing in design?

The consumer might require more from the product they use. Multifunctional, modular, collapsibles and space savers are on the rise. There could be a demand for these products because of smaller accommodation means there needs to be flexibility. Or, is it that that interchangeability of a product allows it to be more personal and interactive?

**"Style is an odd thing; it's in the eye of the beholder."**

106 Life and Style magazine | May 2013 Life and Style magazine | May 2013 107



\* S Q 2 2 H 0 1 2 3 \*

ADDITIONAL SPACE FOR ANSWERS

MARKS DO NOT  
WRITE IN  
THIS  
MARGIN

--



\* S Q 2 2 H 0 1 2 4 \*



ADDITIONAL SPACE FOR ANSWERS

MARKS DO NOT  
WRITE IN  
THIS  
MARGIN



\* S Q 2 2 H 0 1 2 5 \*

*Acknowledgement of Copyright*

Questions 3, 6, and 7 graphics created using images from [www.shutterstock.com](http://www.shutterstock.com)



\* S Q 2 2 H 0 1 2 6 \*



National  
Qualifications  
SPECIMEN ONLY

---

SQ22/H/01

Graphic  
Communication

## Marking Instructions

---

These Marking Instructions have been provided to show how SQA would mark this Specimen Question Paper.

The information in this publication may be reproduced to support SQA qualifications only on a non-commercial basis. If it is to be used for any other purpose, written permission must be obtained from SQA's Marketing team on [permissions@sqa.org.uk](mailto:permissions@sqa.org.uk).

Where the publication includes materials from sources other than SQA (ie secondary copyright), this material should only be reproduced for the purposes of examination or assessment. If it needs to be reproduced for any other purpose it is the user's responsibility to obtain the necessary copyright clearance.

## General Marking Principles for Higher Graphic Communication

*This information is provided to help you understand the general principles you must apply when marking candidate responses to questions in this Paper. These principles must be read in conjunction with the detailed marking instructions, which identify the key features required in candidate responses.*

- (a) Marks for each candidate response must always be assigned in line with these General Marking Principles and the Detailed Marking Instructions for this assessment.
- (b) Marking should always be positive. This means that, for each candidate response, marks are accumulated for the demonstration of relevant skills, knowledge and understanding: they are not deducted from a maximum on the basis of errors or omissions.
- (c) For each candidate response, the following provides an overview of the marking principles. Refer to the Specific Marking Instructions for further guidance on how these principles should be applied.

### (i) Questions that ask candidates to **describe**

Candidates must provide a statement or structure of characteristics and/or features. This should be more than an outline or a list. Candidates may refer to, for instance, a concept, experiment, situation, or facts in the context of and appropriate to the question. Candidates will normally be required to make the same number of factual/appropriate points as are awarded in the question.

### (ii) Questions that ask candidates to **explain**

Candidates must generally relate cause and effect and/or make relationships between things clear. These will be related to the context of the question or a specific area within a question.

### (ii) Questions that ask candidates to **compare**

Candidates must generally demonstrate knowledge and understanding of the similarities and/or differences between, for instance, things, methods, or choices. These will be related to the context of the question or a specific area within a question.

- (d) Candidates can respond to any question using text, sketching, annotations or combinations where they prefer. No marks shall be awarded for the quality of sketching. Marking will relate only to the information being conveyed.

Marking Instructions for each question

Question			Expected response	Max mark	Additional guidance
1	a	i	<p><b>Re-drawing</b></p> <p>Advantages can cover:</p> <ul style="list-style-type: none"> <li>• option to add in layers</li> <li>• easy to edit/modify</li> <li>• can use in simulations</li> <li>• produces vector graphic</li> <li>• small file size</li> <li>• updated drawings to include modern drawing standards</li> </ul> <p>or any other appropriate response.</p> <p>Disadvantages can cover:</p> <ul style="list-style-type: none"> <li>• very time consuming</li> <li>• mistakes could be made</li> </ul> <p>or any other appropriate response.</p> <p><b>Scanning</b></p> <p>Advantages can cover:</p> <ul style="list-style-type: none"> <li>• speed</li> <li>• file can be archived</li> <li>• file can be emailed</li> <li>• files are easily viewed on many electronic devices</li> </ul> <p>or any other appropriate response.</p>	4	<p>Four appropriate comparisons at 1 mark.</p> <p>For 1 mark, the comparison must refer to both methods explicitly or implicitly, eg scanning produces a raster image which cannot be subsequently edited <b>whereas</b> CAD produces a vector image which can be edited (1 mark).</p> <p>Redrawing the image using CAD means that the image can be edited/detail changed in the future (by the original designer or by other people) whereas in a scanned image the detail cannot be edited/changed (1 mark).</p> <p>Redrawing for a building would be very time consuming, in comparison scanning would take a significantly shorter time (1 mark).</p> <p>A bullet point on its own is not acceptable.</p>

Question			Expected response	Max mark	Additional guidance
			<p>Disadvantages can cover:</p> <ul style="list-style-type: none"> <li>• drawings cannot be edited after scanning</li> <li>• file sizes</li> <li>• produces raster graphic</li> <li>• physical drawing sizes may prove too large to scan in one attempt (may require piecing together)</li> </ul> <p>or any other appropriate advantage/disadvantage.</p>		
1	a	ii	<p>Any relevant explanation made regarding:</p> <ul style="list-style-type: none"> <li>• the incompatibility of file types</li> <li>• drawing standards</li> <li>• files cannot be worked on simultaneously by different parties</li> <li>• possible complications in language barriers.</li> </ul>	2	Two appropriate explanations at 1 mark.
1	b		<p>Any appropriate and specific aspect for testing such as:</p> <ul style="list-style-type: none"> <li>• heat flow</li> <li>• flow of people (dynamic)</li> <li>• static loading</li> <li>• strength of material</li> <li>• ventilation flow/rate</li> <li>• light</li> <li>• evacuation time.</li> </ul>	1	One aspect at 1 mark.
1	c		<p>Any appropriate advantage such as:</p> <ul style="list-style-type: none"> <li>• ease of storage</li> <li>• ease of sharing</li> <li>• ease of collaborative working</li> </ul>	1	One advantage at 1 mark.

Question			Expected response	Max mark	Additional guidance
			<ul style="list-style-type: none"> <li>positive environmental aspects</li> <li>reduction in copying</li> </ul> <p>or any other appropriate advantage.</p>		
2	a	i	<p>Description which makes reference to:</p> <ul style="list-style-type: none"> <li>the loft command to join profiles (1 mark)</li> </ul> <p>and</p> <ul style="list-style-type: none"> <li>the size of the profiles (40 mm x 40 mm) and a distance of 120 mm (1 mark)</li> </ul>	2	<p>Two descriptions of appropriate modelling techniques.</p> <p>The twist is not allocated any marks.</p>
2	a	ii	<p>Description which makes reference to:</p> <ul style="list-style-type: none"> <li>extruding a cuboid 40 mm and applying a radius to the end edges (1 mark)</li> </ul> <p>and</p> <ul style="list-style-type: none"> <li>drawing a profile on the end of the 3D model, 40 mm x 40 mm (1 mark)</li> </ul> <p><b>OR</b></p> <ul style="list-style-type: none"> <li>extruding the profile 40 mm (1 mark)</li> </ul> <p>and</p> <ul style="list-style-type: none"> <li>drawing a profile the shape indicated on the sketch (1 mark)</li> </ul>	2	Two descriptions of appropriate modelling techniques.
2	b		<p>A description which makes reference to:</p> <ul style="list-style-type: none"> <li>using the shell solid command to remove interior material from the solid model (1 mark)</li> </ul>	4	<p>The response must be in the correct order.</p> <p>Where the order is incorrect then 0 marks should be awarded.</p>

Question	Expected response	Max mark	Additional guidance
	<p>and</p> <ul style="list-style-type: none"> <li>• creating a sketch through the solid model (lengthways). The sketch must be bigger than the solid model (1 mark)</li> </ul> <p>and</p> <ul style="list-style-type: none"> <li>• extruding the sketch with a cut/subtraction in one direction and saving the file (1 mark)</li> </ul> <p>and</p> <ul style="list-style-type: none"> <li>• redefining the modelling tree/extrusion and cut/subtract in the opposite direction and saving the file under a different name (1 mark)</li> </ul> <p><b>OR</b></p> <ul style="list-style-type: none"> <li>• creating a sketch through the solid model (lengthways) – the sketch must be bigger than the solid model (1 mark)</li> </ul> <p>and</p> <ul style="list-style-type: none"> <li>• extruding the sketch with a cut/subtraction in one direction (1 mark)</li> </ul> <p>and</p> <ul style="list-style-type: none"> <li>• using the shell command to remove a face and hollow the model and then saving the file (1 mark)</li> </ul> <p>and</p> <ul style="list-style-type: none"> <li>• redefining the modelling tree/extrusion and cut/subtract in the opposite direction and saving the file under a different name (1 mark)</li> </ul> <p>or any other suitable <b>top down</b> approach in the correct order</p>		



Question		Expected response	Max mark	Additional guidance
2	c	<p>An explanation of the appropriateness of inclusion of the item such as:</p> <ul style="list-style-type: none"> <li>• removes repetition</li> <li>• saves time on drawing common or complex components</li> <li>• common components in a CAD library are likely to conform to standards</li> <li>• accurately represent common or frequently used parts</li> <li>• library components can be used or shared between a wide range of models</li> <li>• library components can be used or shared between a wide range of technicians, operators or people</li> </ul> <p>or any other appropriate explanation.</p>	2	Two appropriate explanations at 1 mark.
2	d	<p>An outline description which makes reference to constraining methods, eg:</p> <ul style="list-style-type: none"> <li>• centre the axis of two corresponding screw-bosses or centre the axis of the two corresponding radiused case components (1 mark)</li> </ul> <p>and</p> <ul style="list-style-type: none"> <li>• mate the two flat faces on the components, either on the outer case or the bosses (1 mark)</li> </ul> <p>OR</p> <ul style="list-style-type: none"> <li>• any other appropriate description</li> </ul>	2	Two correct and ordered methods at 1 mark
2	e	<p>Production of a modelling plan which communicates how <b>key</b> features of the 3D model are generated in relation to the criteria of the question.</p>	4	The order of the plan is not critical, just as long as the plan produced would work.

Question	Expected response	Max mark	Additional guidance
	<p>Responses should include references to:</p> <ul style="list-style-type: none"> <li>• 140 mm between centres (1 mark)</li> <li>• minimum 30 mm clearance for handle (1 mark)</li> <li>• 10 mm diameter for the handle (1 mark)</li> <li>• any suitable modelling technique to complete the handle (1 mark)</li> </ul> <p>or within any other workable modelling plan.</p>		
3	<p>Explanations should make appropriate reference to (and relate the choices made to):</p> <ul style="list-style-type: none"> <li>• Target market (consumer) <ul style="list-style-type: none"> <li>- families</li> <li>- hygiene aware</li> <li>- families with young children</li> </ul> </li> <li>• Colour scheme/choice of images <ul style="list-style-type: none"> <li>- fresh</li> <li>- hygienic</li> <li>- calm</li> <li>- natural</li> <li>- health</li> <li>- safety</li> <li>- link to broccoli (fresh, organic, natural)</li> </ul> </li> <li>• Typeface <ul style="list-style-type: none"> <li>- sans serif font</li> <li>- modern</li> <li>- use of product logo to promote brand</li> <li>- use of uppercase to emphasise the bio/eco aspect of the product</li> </ul> </li> </ul> <p>or any other appropriate description.</p>	4	<p>To achieve full marks, candidates should make reference to all three topics, ie target market (consumer), colour scheme and typeface, and include an appropriate explanation for their use/choice, as follows:</p> <ul style="list-style-type: none"> <li>• Reference to two topics and appropriate explanation of each (3 marks)</li> <li>• Reference to one topic and appropriate explanation (2 marks)</li> <li>• Some reference to topics, insufficient depth or appropriateness (1 mark)</li> </ul>

Question			Expected response	Max mark	Additional guidance
4	a	i		3	<p>There are 10 areas of hatching which could be shown.</p> <ul style="list-style-type: none"> <li>• 8–10 areas (3 marks)*</li> </ul> <p>*To achieve full marks candidates must <b>not</b> hatch the web, bolt and nut.</p> <ul style="list-style-type: none"> <li>• 4–7 areas (2 marks)</li> <li>• 1–3 areas (1 mark)</li> </ul>
4	a	ii	Web	1	

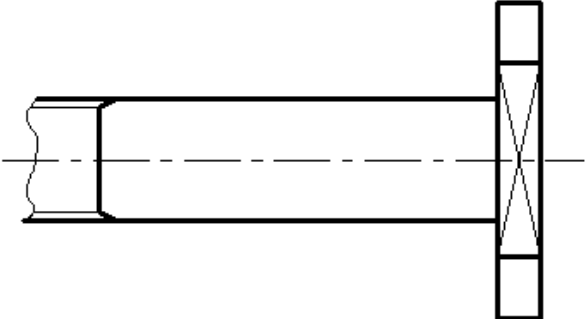
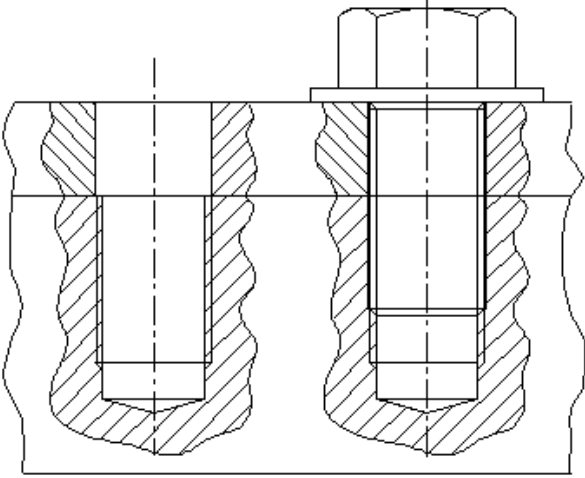
Question			Expected response	Max mark	Additional guidance
4	a	iii		1	Two diagonal lines should be shown in the correct area (1 mark).
4	b	i		2	<p>British Standards hatching convention shown correctly on stage 1 and hatching shown inside thread area (1 mark)</p> <p>British Standards hatching convention shown correctly on stage 2 and hatching shown inside thread area below the bolt (1 mark)</p> <p>No marks are awarded for the hatching on the top plate</p>
4	b	ii	A blind hole is a hole that is drilled or milled to a specified depth without breaking through to the other side of the material.	1	

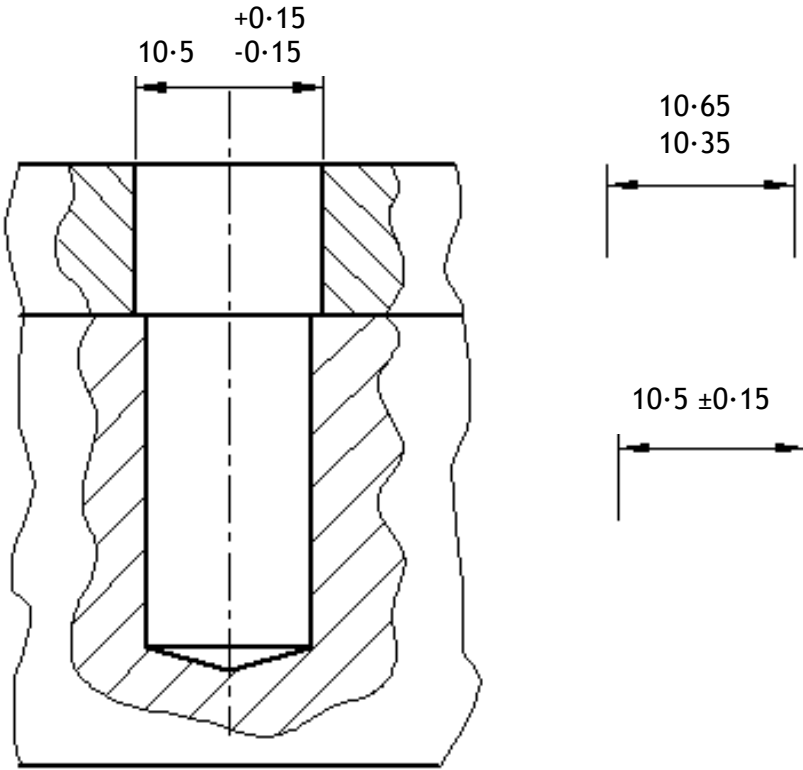
Question			Expected response	Max mark	Additional guidance
4	b	iii	Metric	1	
4	b	iv	30 mm	1	30 mm $\pm$ 1mm
4	b	v	Local or part section	1	
4	b	vi		1	<p>Correct British Standards tolerances applied to the view in stage 1.</p> <p>Any one of the three variants can be used.</p>

Question		Expected response	Max mark	Additional guidance																		
5	a	<table border="1"> <thead> <tr> <th>Generator line</th> <th>Offset from line X (mm) (within the ranges)</th> </tr> </thead> <tbody> <tr> <td>1</td> <td>13-15</td> </tr> <tr> <td>2</td> <td>18.5-20.5</td> </tr> <tr> <td>3</td> <td>27.5-29.5</td> </tr> <tr> <td>4</td> <td>37.5-39.5</td> </tr> <tr> <td>5</td> <td>37-39</td> </tr> <tr> <td>6</td> <td>37.5-39.5</td> </tr> <tr> <td>7</td> <td>36.5-38.5</td> </tr> <tr> <td>Circle centre point</td> <td>17-19</td> </tr> </tbody> </table>	Generator line	Offset from line X (mm) (within the ranges)	1	13-15	2	18.5-20.5	3	27.5-29.5	4	37.5-39.5	5	37-39	6	37.5-39.5	7	36.5-38.5	Circle centre point	17-19	2	<p>For full marks, seven correct dimensions for points and one centre point within stated ranges.</p> <ul style="list-style-type: none"> <li>6–8 correct (2 marks)</li> <li>1–5 correct (1 mark)</li> </ul> <p>Dependent upon local printer settings, the size of the image in this question for surface X and line X may be at variance with the answer stated. In such circumstances, markers should make the necessary adjustment to the answer taking account of the variance and the tolerance.</p>
Generator line	Offset from line X (mm) (within the ranges)																					
1	13-15																					
2	18.5-20.5																					
3	27.5-29.5																					
4	37.5-39.5																					
5	37-39																					
6	37.5-39.5																					
7	36.5-38.5																					
Circle centre point	17-19																					
5	b	<p>Candidate's response must be within the following ranges:  X=57–58 mm      Z = 49–51 mm</p>	1	<p>Within the ranges given.</p> <p>Dependent upon local printer settings, the size of the image in this question for surface A and the elevation may be at variance with the answer stated. In such circumstances, markers should make the necessary adjustment to the answer taking account of the variance and the tolerance.</p>																		
6	a	<p>Explanations such as:</p> <ul style="list-style-type: none"> <li>The serif fonts are formal, traditional or old fashioned.</li> <li>They represent a more sophisticated or mature look to appeal to the older target market.</li> <li>The flicks and flowing curves in the font styles look friendly and safe to an older target market.</li> <li>Each letter flowing into the next makes it easier for an older target market to read.</li> </ul> <p>or any other appropriate explanation.</p>	2	<p>Two explanations at 1 mark.*</p> <p>*It is not sufficient to state that it appeals to the older target market.</p>																		

Question		Expected response	Max mark	Additional guidance
6	b	<p>Explanations such as:</p> <ul style="list-style-type: none"> <li>• The page is rectilinear and so are the boxes, lines and the square.</li> <li>• The cropped images create curved or natural shapes that bring eye-catching contrast with/visual interest against the rectilinear shapes.</li> <li>• The cropped cyclist and helmet (the product) stand out against a simple geometric backdrop.</li> <li>• The punctuation circles add contrast against the rectilinear shapes in the layout.</li> </ul> <p><b>OR</b></p> <ul style="list-style-type: none"> <li>• The curved text above the cyclist creates contrast with the rectilinear shapes in the layout.</li> <li>• The purpose of the advert is to attract attention quickly; the contrasting shapes (mentioned earlier) help ensure this.</li> <li>• The curved text mimics (harmonises with) the shape of the helmet and appears to protect the cyclist's head.</li> </ul> <p>or any other appropriate explanation.</p>	2	Two explanations at 1 mark.
6	c	<p>Explanations such as:</p> <p>The orange line:</p> <ul style="list-style-type: none"> <li>• creates a unifying accent colour with the other orange items</li> <li>• creates depth by passing behind the cyclist</li> <li>• underlines (emphasises) part of the slogan.</li> </ul>	3	<p>Three explanations at 1 mark.*</p> <p>*1 mark for each line colour explanation; 0 marks for repeated answers.</p>

Question		Expected response	Max mark	Additional guidance
		<p>The blue vertical line:</p> <ul style="list-style-type: none"> <li>• creates depth by passing behind the helmet</li> <li>• creates eye-catching contrast with the horizontal lines</li> <li>• harmonises with the horizontal blue line</li> <li>• separates the space for the web address.</li> </ul> <p>The blue horizontal line:</p> <ul style="list-style-type: none"> <li>• connects the layout items horizontally</li> <li>• aids alignment with the slogan and company name</li> <li>• creates eye-catching contrast with the orange colours</li> <li>• harmonises with the vertical blue line</li> <li>• creates a vertical/horizontal contrast</li> <li>• separates the space for the company name.</li> </ul> <p>or any other appropriate explanation.</p>		One explanation from each set.
6	d	<p>The advancing colour is red or orange.</p> <p>A description such as:</p> <p>The effect this colour has on the layout is that:</p> <ul style="list-style-type: none"> <li>• it lifts the red or orange items forward</li> <li>• makes the red or orange items more prominent</li> <li>• makes the red or orange items stand out more</li> <li>• creates contrast with the receding colours in the layout</li> </ul> <p>or any other appropriate description.</p>	2	<p>Correct identification of advancing colour at 1 mark</p> <p>Appropriate description of the effect at 1 mark</p>



Question			Expected response	Max mark	Additional guidance
6	e	i	<p>An explanation such as:</p> <ul style="list-style-type: none"> <li>It leaves two awkward spaces to fill rather than one usable space/It misses the most natural focal points.</li> </ul> <p>or any other appropriate explanation.</p>	1	<p>One explanation at 1 mark.*</p> <p>*The same answer cannot be used for e(i) and e(ii).</p>
6	e	ii	<p>An explanation such as:</p> <ul style="list-style-type: none"> <li>It will create visual interest through asymmetry, white space, and a natural focal point.</li> <li>It leaves a single space that is easier to fill/populate.</li> </ul> <p>or any other appropriate explanation.</p>	1	<p>One explanation at 1 mark.*</p> <p>*The same answer cannot be used for e(i) and e(ii).</p>
6	f		<p>An explanation such as:</p> <ul style="list-style-type: none"> <li>The font is a graffiti/grungy/sans serif style and is fun and youthful.</li> <li>Images of mountain bike stunts connect with target market.</li> <li>Tilted images and items make the layout less formal and create visual interest.</li> <li>Bold, contrasting colours (blue and red) create a youthful look.</li> <li>Distressed images will appeal to young target market.</li> </ul> <p>or any other appropriate explanation.</p>	3	<p>Three explanations at 1 mark.</p>
7	a		<p>Explanation for headers and footers such as:</p> <ul style="list-style-type: none"> <li>They can assist in navigating within a document.</li> <li>They display useful information including, title/chapter, page number, date, author.</li> </ul>	2	<p>Two explanations at 1 mark.</p>

Question			Expected response	Max mark	Additional guidance
			<ul style="list-style-type: none"> <li>• They identify the document's content.</li> <li>• They create a sense of unity throughout a document or section.</li> </ul>		
7	b	i	Crop marks	1	One identification at 1 mark.
7	b	ii	Explanation such as: <ul style="list-style-type: none"> <li>• Crop marks illustrate the boundary where the document is to be cut after printing.</li> </ul>	1	One explanation at 1 mark.
7	b	iii	Explanation such as: <ul style="list-style-type: none"> <li>• To bleed is to extend a graphic or image frame beyond a trimmed edge of the page.</li> <li>• To ensure the graphic or image extends to the very edge of the page of a document.</li> <li>• Edge to edge printing.</li> </ul>	1	One explanation at 1 mark.
7	c		Description of layering such as: <ul style="list-style-type: none"> <li>• Layering can support in creating a master page for future documents.</li> <li>• Layering allows graphics and text to be edited separately.</li> <li>• Layering supports image manipulation and can occur on separate layers.</li> <li>• Layers can be duplicated and linked to other layers.</li> <li>• Layers can be turned off or on to aid clarity.</li> <li>• Layers can be brought forward or backward as necessary.</li> </ul>	2	Two descriptions at 1 mark.

Question			Expected response	Max mark	Additional guidance
7	d	i	<p>Explanation of impact of <b>use of reverse</b> such as:</p> <ul style="list-style-type: none"> <li>• offsets the main text from the headline/sub-headline</li> <li>• lightens the layout (decreases the value).</li> </ul>	2	0 marks awarded for referencing design elements or design principles.
7	d	ii	<p>Explanation of impact of <b>dropped capital</b> such as:</p> <ul style="list-style-type: none"> <li>• emphasises the start of a paragraph</li> <li>• signifies the main text column.</li> </ul>	2	0 marks awarded for referencing design elements or design principles.
7	d	iii	<p>Explanation of impact of when the <b>main text column is converted from one to two columns</b> such as:</p> <ul style="list-style-type: none"> <li>• follows a standard method of presenting a main body of text</li> <li>• assists with the readability of the document.</li> </ul>	2	0 marks awarded for referencing design elements or design principles.

[END OF SPECIMEN MARKING INSTRUCTIONS]