

STAPLE HERE

FOR OFFICIAL USE

--	--	--	--	--	--

X033/701

NATIONAL
QUALIFICATIONS
2011

WEDNESDAY, 1 JUNE
9.00 AM – 12.00 NOON

GRAPHIC
COMMUNICATION
ADVANCED HIGHER

Fill in these boxes and read what is printed below.

Full name of centre

Town

Forename(s)

Surname

Date of birth

Day Month Year

--	--	--	--	--	--	--	--

Scottish candidate number

--	--	--	--	--	--	--	--	--	--

Number of seat

80 marks are allocated to this paper.

- 1 Answer **all** questions.
- 2 Read each question carefully before you answer.
- 3 Written answers may be in **ink** or **pencil**.
- 4 Drawings and sketches **must be in pencil**.
- 5 Coloured pencils may be used when sketching.
- 6 Dimensions are given in millimetres or as stated.
- 7 Orthographic drawings are in third angle projection.
- 8 The leaflet for Questions 1, 2 and 3 has been supplied separately. Please ensure that you have this leaflet.
- 9 **At the end of the examination**
 - check that your name is on every sheet;
 - put the sheets in correct numerical order;
 - place this sheet on top of the others;
 - join all sheets together by **stapling** at the top left-hand corner;
 - before leaving the examination room, you must give these sheets to the Invigilator (if you do not you may lose all the marks for this paper).

Marks Grid

Question	Marks
1	
2	
3	
4	
5	
6	
7	
8	
9	
10	
Total Marks	



ACKNOWLEDGEMENTS

Leaflet for use with Questions 1, 2 and 3—Double page spread is taken from *Blue Magazine* by O2, Issue 11, August 2008. Permission is being sought from O2 UK Ltd.

Leaflet for use with Questions 1, 2 and 3—Pictures in spread from *Blue Magazine* by O2, Issue 11, August 2008, are reproduced by kind permission of Rex Features.

Leaflet for use with Questions 1, 2 and 3—Pictures in spread from *Blue Magazine* by O2, Issue 11, August 2008 are acknowledged to two sources, one of them being Getty. Permission is being sought from Getty Images.

1

Please refer to the "Events at The O₂" leaflet.
Identify and describe **three Design Principles** that make an impact.

Principle 1

Description:

Principle 2

Description:

Principle 3

Description:

Total (6)

2

Please refer to the "Events at The O₂" leaflet.

Annotate the leaflet to show:

- Footer
- Bleed
- Headline
- Gutter
- Reverse Text
- Rule

Total (6)

3

Study the "Events at The O₂" leaflet.
Identify and describe **three Design Elements** that make an impact on this page.

Design Element 1

Description:

Design Element 2

Description:

Design Element 3

Description:

Total (6)

4

Two different types of balance are shown in the graphic items below. With reference to Design Principles:

- (a) name the type of balance;
- (b) describe how the balance is applied in each composition.

1 Name of balance

Description



2 Name of balance

Description

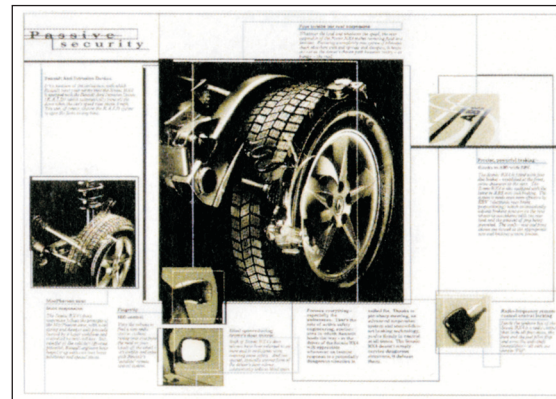

Total (4)

5

The following commands are associated with Computer-Aided 3D Modelling.

- Solid Primitive
- Boolean Intersection
- Ruled Surface
- Revolution

Describe, with the aid of sketches, any **three** of the 3D modelling commands.

Command 1

Description

Command 2

Description

Command 3

Description

Total (6)

6

Describe the printing terms listed below.

- Crop marks
- Pantone ©
- CMYK
- Registration

Crop Marks

Pantone ©

CMYK

Registration

Total (4)

7

Describe the following Paper/Printing terms.

- Opacity
- Paper Weight

Opacity

Paper Weight

Total (2)

The incomplete plan and incomplete elevation of interpenetrating cylindrical and square pipes are given.

Draw, in the position shown:

- (a) the complete plan and elevation;
- (b) the end elevation;
- (c) the surface development of the square pipe starting at corner **X**.

Include all Hidden Detail.

(16 marks)

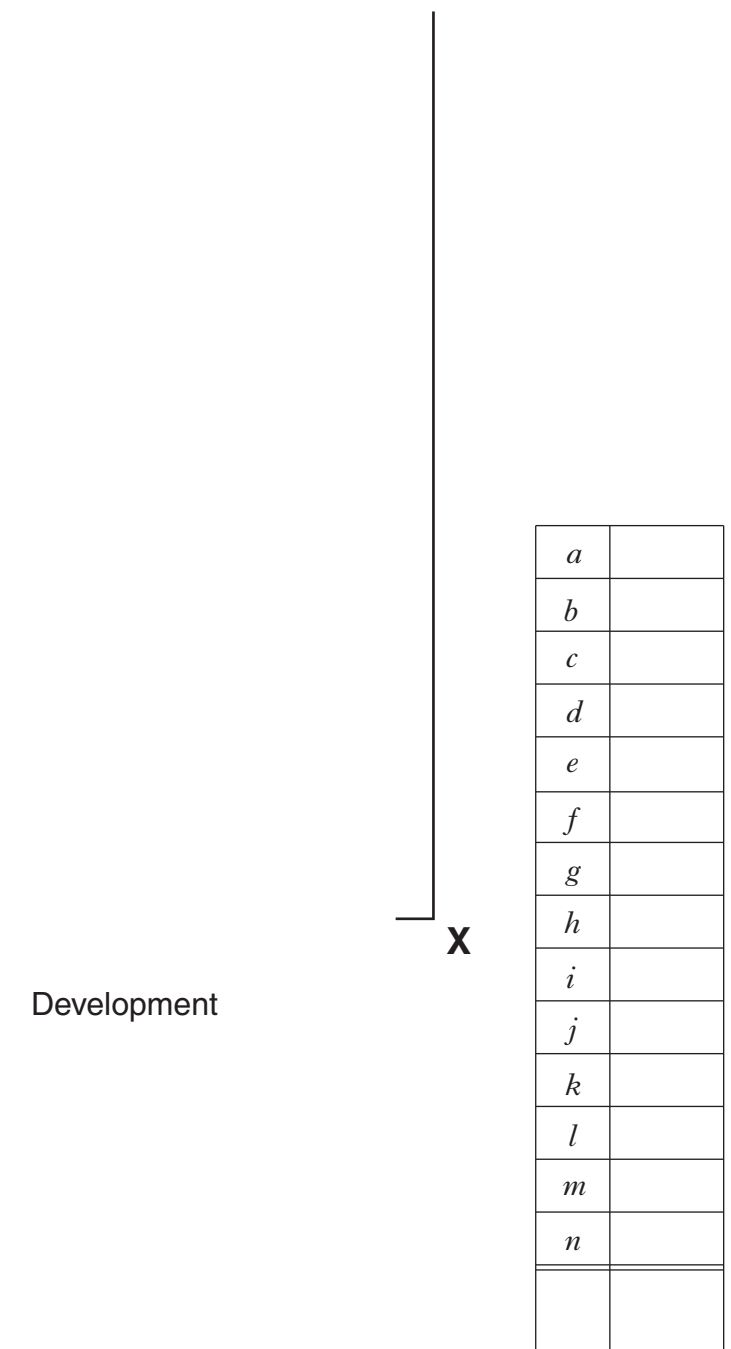
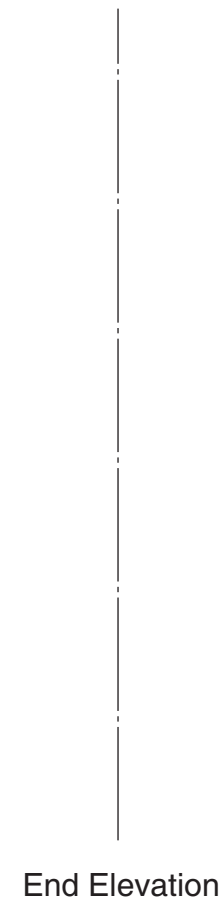
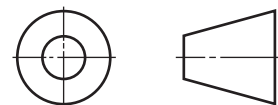
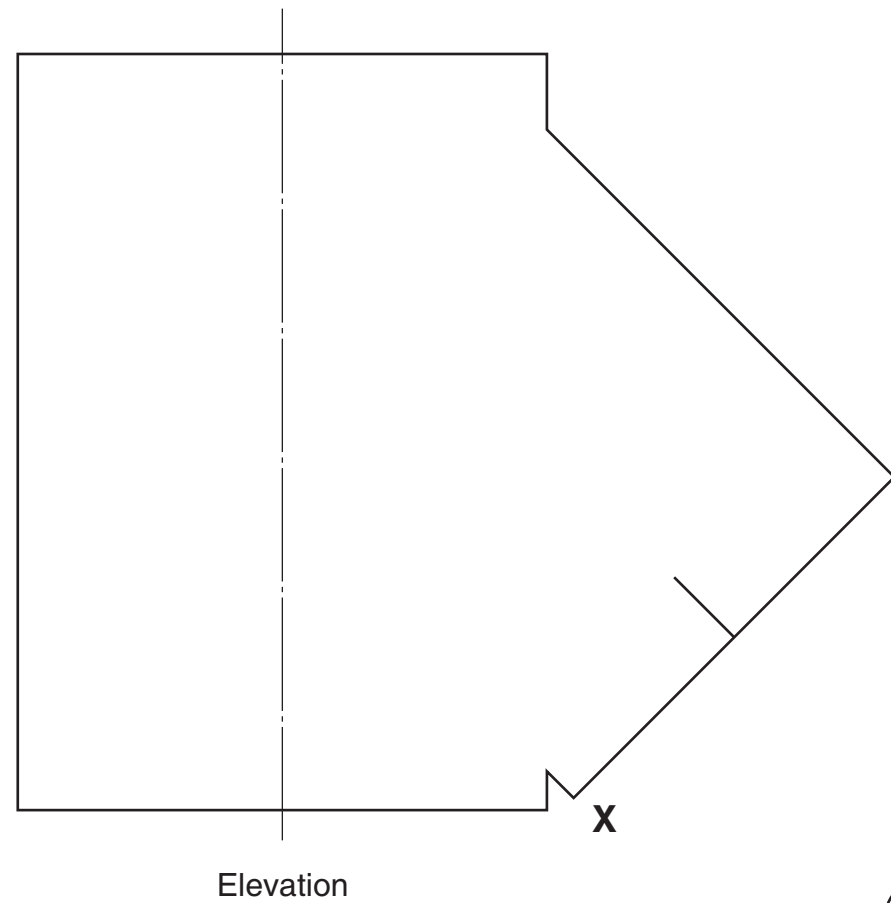
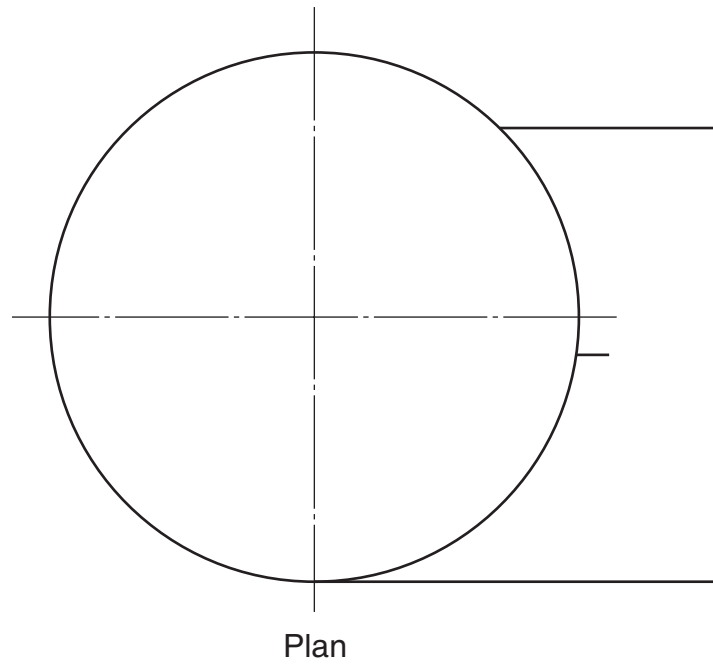

The plan and elevation of a transition piece are given.

Draw, in the position indicated, the surface development cut along seam **AA**.

(14 marks)

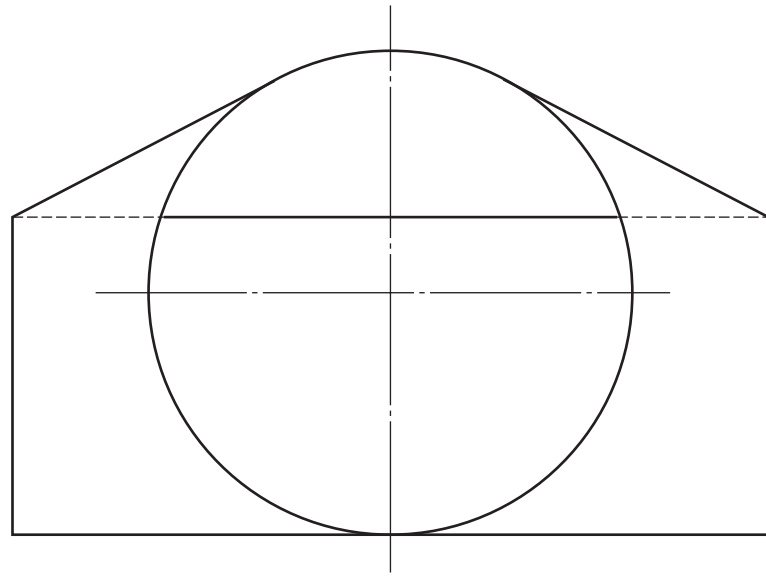

PLAN

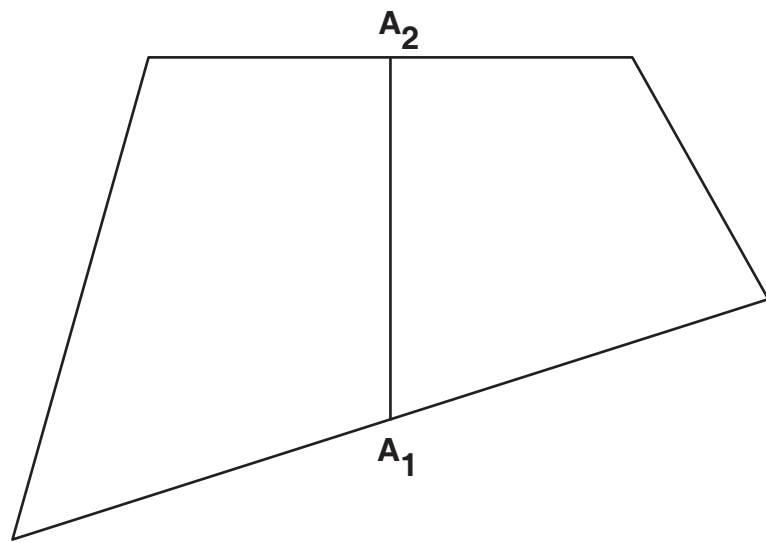

ELEVATION

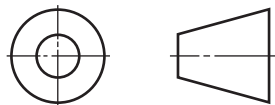

<i>a</i>	
<i>b</i>	
<i>c</i>	
<i>d</i>	
<i>e</i>	
<i>f</i>	
<i>g</i>	
<i>h</i>	
<i>i</i>	
<i>j</i>	
<i>k</i>	
<i>l</i>	
<i>m</i>	
<i>n</i>	

A₂

A₁

Candidate's Name _____

10

The plan of a solid oblique cone is given.

Draw:

- (a) the complete elevation;
- (b) the end elevation;
- (c) the true shape of the surface indicated by arrow **A**.

Show all hidden detail.

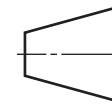
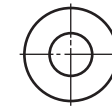

Section B

10

(16 marks)

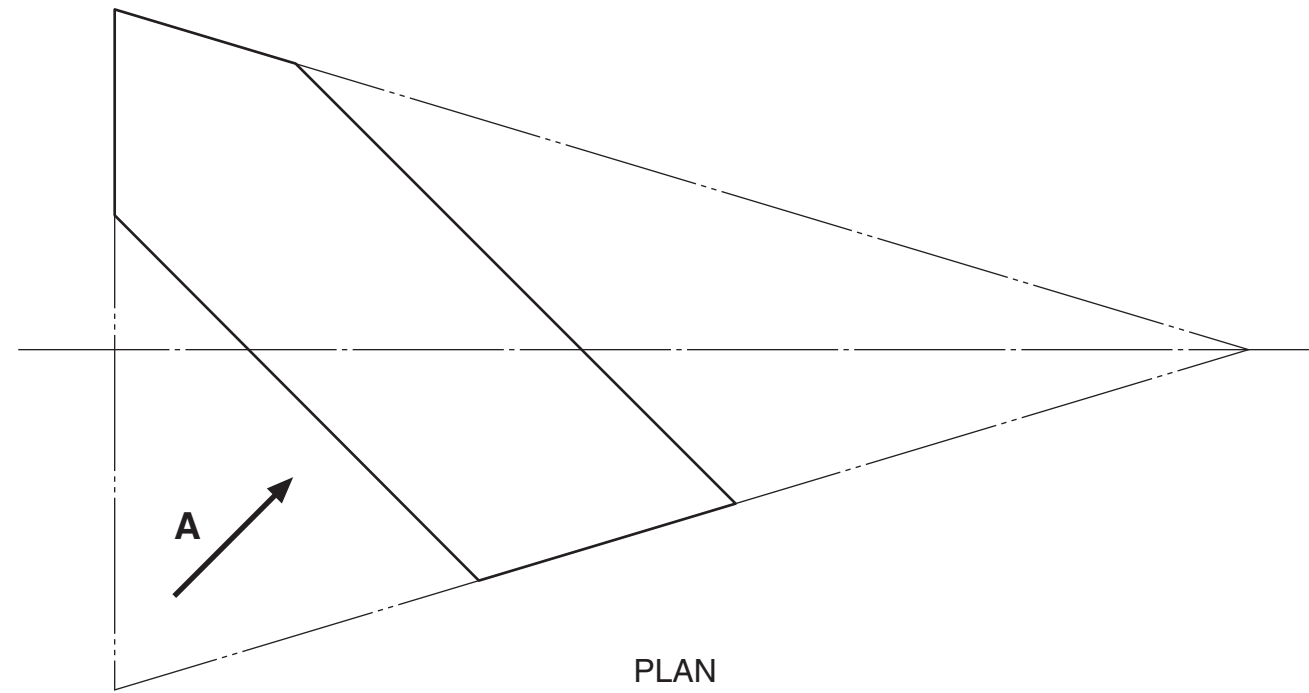

TRUE SHAPE

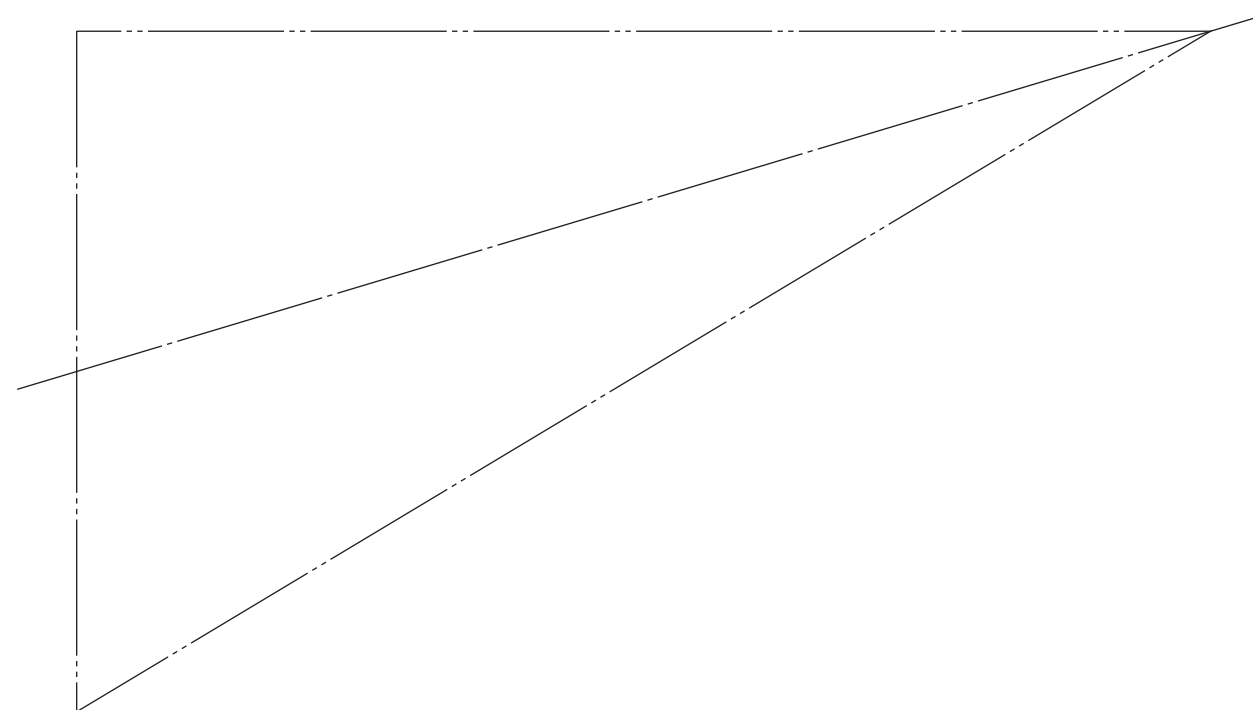

ELEVATION

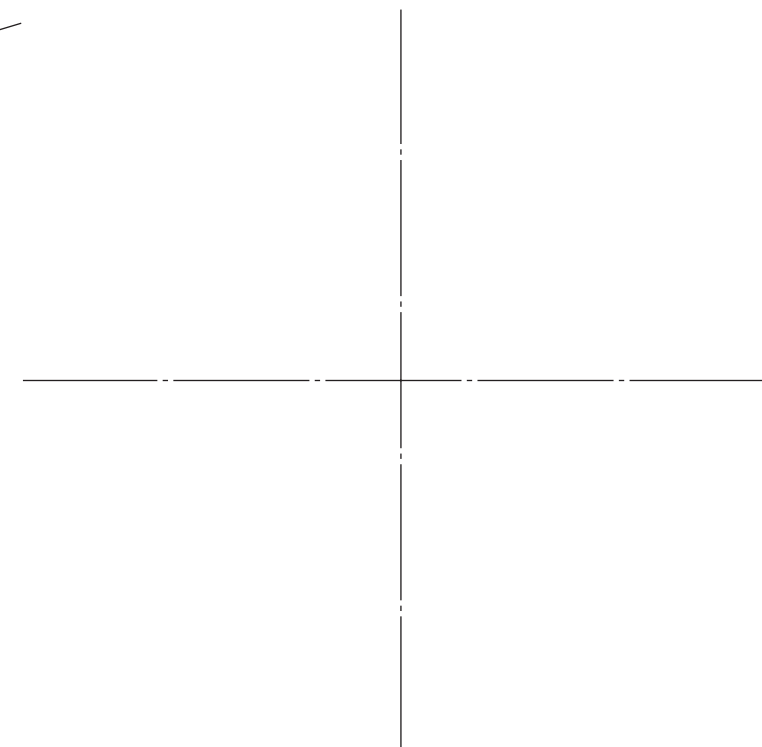

END ELEVATION

<i>a</i>	
<i>b</i>	
<i>c</i>	
<i>d</i>	
<i>e</i>	
<i>f</i>	
<i>g</i>	
<i>h</i>	
<i>i</i>	
<i>j</i>	
<i>k</i>	
<i>l</i>	
<i>m</i>	
<i>n</i>	

X033/702

NATIONAL
QUALIFICATIONS
2011

WEDNESDAY, 1 JUNE
9.00 AM - 12.00 NOON

GRAPHIC
COMMUNICATION
ADVANCED HIGHER

Leaflet for use with
Questions 1, 2 and 3



what's on...

Your monthly guide to the UK's premier entertainment venue

Events at The O₂



PARTY LIKE A V.I.P. IN THE O₂'S BLUEROOM!

If you're heading to a show at The O₂, make a proper night of it by taking advantage of some of the other things we have on offer, like the blueroom bar...

The sumptuous blueroom bar is only open during arena events and is exclusively for the use of a limited number of O₂ customers per night. If you text BLUEROOM to 60202 while you're at The O₂, you will be one of the lucky 200 people at every show to receive an electronic entry ticket via text. Don't worry if your pals aren't on O₂, as everyone who bags a blueroom ticket can bring three friends with them!

"EVERYONE WHO BAGS A BLUEROOM TICKET CAN BRING THREE FRIENDS WITH THEM, ABSOLUTELY FREE OF CHARGE"

The bar is filled with comfy sofas, chilled-out lighting, a jukebox with thousands of tunes and screens showing an ever-changing array of wallpapers. Got a picture you want to share? Text it to 60202 and we'll screen it on the walls. Plus, every night is different in the blueroom as its theme changes to suit what's happening in the O₂ that night, so you can enjoy a total event experience! (See Bar Themes for details.)

The blueroom bar is just one of the exciting choices for O₂ customers when you visit The O₂. Make sure that you text BLUEROOM to 60202 and don't miss out!



BLUEROOM: BAR THEMES

O₂ Goes 80s

Over the top cocktails, cheesy tunes and classic arcade games!

O₂ Goes Diva

Shake the blueroom with your entourage and try our Diva Cocktails.

O₂ Rock Takeover

From rock classics to modern anthems, we'll be playing them all at the Indie Disco.

O₂ Fan Zone

Set your pulse racing with a host of great games, such as foosball, golf and digi-darts.

O₂ Goes Pop

Get ready to party in the blueroom bar with our popstastic disco!

O₂ The Legends

Enjoy pre-event performances of all-time classics from our live jazz trio.

O₂ For The Family

Munch candy floss and popcorn and let the best face painters in the business work their magic.

O₂ Sofa Sessions

Chill out in the blueroom bar to a live acoustic set. Enjoy a glass of wine and a massage from an O₂ angel.

PRIORITY TICKETS

For a full list of what's on at The O₂ text INFO to 60202. As an O₂ customer you can get priority tickets to The O₂ – visit o2.co.uk/theo2 to register

LAST CHANCE TO BOOK FOR...

Henry Rollins

12 August

From hardcore punk to acting and writing, Rollins has done it all. Catch his spoken word show at indigO₂.

THIS MONTH

Mysteries of Tutankhamun Revealed

19 August

Egypt's chief archaeologist Zahi Hawass shares the latest exciting discoveries at this lecture in indigO₂.



NEXT MONTH

GB Basketball

6 September

Now is the time to book for an evening of intense basketball action as Great Britain takes on the Czech Republic at The O₂. An absolute must for fans of this thrill-a-minute sport.

Stevie Wonder

11, 12 & 30 September, 1 October

The musical icon that is Stevie Wonder is touring Europe for the first time in nearly ten years. Don't miss this rare chance to see a genuine legend in action, playing all of his greatest hits at The O₂.

COMING SOON

James Blunt

14 October

This final night of James Blunt's All The Lost Souls UK tour is guaranteed to be one to remember.

BOOK NOW FOR
Canadian rockers
Nickelback, eighties
icon **Howard Jones**,
ska faves **Madness**,
and the timeless **Tina**
Turner. To book go to
theo2.co.uk/inside/book-now

Paper edge

PICTURES: GETTY, REX FEATURES



BOOK NOW

THE BLUEROOM

The O₂
Peninsula Square,
London, SE10 0DX
T: 0844 856 0202
theo2.co.uk/inside/book-now